

GEN HMK **220 LC**
SERIES EXCAVATOR



HIDROMEK[®]



HEAVY DUTY TYPE

HMK 220LC has been designed by HÍDROMEK engineers after careful evaluation of working conditions and operator demands and has been released on the market afterward as a crawler excavator that meets all expectations of users. All fabricated parts including boom, arm, bucket, undercarriage, lower and upper frames have been designed and produced as heavy duty type. HMK 220LC offers its operator maximum efficiency by providing trouble-free and continuous operating performance even in the toughest of working conditions. When such rigorous care at the design stage of HMK 220LC is combined with worldwide approved components and state-of-the-art production technologies, the outcome has been a high performance, durable, comfortable, and well-balanced product with low maintenance and operation costs.

CAB

HMK 220LC excavator cabin has been designed to allow the operator to work comfortably even under the hardest conditions.

Cabin entrance is large enough to enable the operator to enter the cab easily with plenty of clearance. Opening windscreen is designed to give the operator a perfect visibility. It is possible to open the windscreen by sliding it towards the roof. Rear window may be removed and kept under the operator seat. Other features enhancing operator's comfort are the ergonomic seat and front console.

The standard operator seat of the HMK 220LC can be adjusted in 9 different positions and is designed to enable operator to work without fatigue and comfortably with high performance for long hours. Besides, the joystick console and seat can move independently from each other which lets the operator to adjust the most suitable position for him.

The seat is equipped with seat belt as a safety precaution. The cab is supported by 6 silicon viscose mounts that dampen the effects of noise, shock and vibrations regardless of working conditions of the machine and the optional attachment on it. Also a high capacity air conditioning system is located on the cab to create the optimum working environment for the operator.



ENGINE

“An Extraordinary Engine”



Diesel Engine

Max. Power (SAE J1995) : 162 HP (120,7 kW) @2000 rpm
Max. Torque : 656 Nm @1500 rpm

An extraordinary engine...

The Isuzu engine fitted in the HMK 220LC is specially developed for excavator applications. It is a turbo diesel engine, complies with the U.S and EU Emission Regulations, with 4 cylinders, 4 cycles, water-cooling, turbocharger and intercooler. High performance, long life and reliability of the engine under all working conditions have been proved in many different markets.

Low fuel consumption...

The direct fuel injection and intercooler features not only provide less fuel consumption but also increase the power and torque produced by the engine by providing more efficient combustion.

More than standard...

HIDROMEK always offers more than what is expected from any construction equipment. Some of the standard features offered along with HMK 220LC model are:

- Air pre-heating function to start-up engine easily in cold weather conditions
- Diesel fuel/water separator
- No disturbance for the environment and operator due to low exhaust gas emission and sound level.

“Reinforced Heavy Duty Type Construction”



SUB-FRAME & UNDERCARRIAGE

X' box type sub-frame

'X' shape box type sub-frame has perfect resistance against bending forces and vibration stress since it homogeneously distributes the stress exposed on it.

Resistance

The lower rollers are connected to the sub-frame by pentagon shape fittings enhance the strength of the frame and lifetime of the frame, too. Modern production technologies and precise quality control systems make “zero-error” production possible.

The standard long track maximizes the balance of the machine by providing a durable platform for the machine to work on. Two roller housings in each track keep track chains in straight direction and therefore prevent corrosion of lower rollers.

The upper roller, lower rollers and front idlers are suitable for heavy-duty working conditions. They have been sealed with life-time seals which are maintenance-free.

Track pins and bushings are greased and sealed, thus reducing chain noise and extending track life.

600,700,800 mm wide track links with triple grouser are able to self-clean through their holes.

TECHNICAL SPECIFICATIONS

Opera Control System

- Perfect control
- Fuel economy
- Long component life
- Low noise level and exhaust gas emission
- Operator comfort
- Warning and protection (security) features
- Malfunction / fault indication feature
- Auxiliary functions

Opera Control System ,consists of 4 power modes and 3 working modes, helps operator to choose the most suitable working conditions in accordance with requirements of work through perfect matching with diesel engine and hydraulic pump.

MODE SELECTIONS

A-Power Mode Selection

POWER MODE	
F (Sensitive Mode)	This mode is used for light works requiring sensitive movements
E (Economy Mode)	This mode is for light work in which low fuel consumption is desired.
P (Power Mode)	This mode is for general digging and loading works.
HP (High Power Mode)	This mode is for heavy and high speed required

B- Working Mode Selection

WORKING MODE	
D (Digging Mode)	It is designed for normal digging operations.
B (Breaking Mode)	It is designed for breaking operations.
O (Optional attachment Mode)	It is designed to work with optional attachment.

WARNING AND PROTECTION FEATURES

Continuous Monitoring:

Opera Control System, continuously monitors the most important parameters of machine and warns the operator in case of any abnormality in three ways:

- Audio warning
- Warning lights
- Indicators



Overheating Prevention Function:

If engine water temperature and hydraulic oil temperature exceeds certain limits, electronic control system decreases the pump flow rate and engine rpm to enable the machine work continuously.

Automatic preheating :

Automatic preheating provides reaching machine to optimum working temperatures by measuring air intake temperature , cooling water temperature and hydraulic oil temperature of diesel engine. Machine control unit removes engine rpm from idling to 1200 rpm when engine cooling water is lower than 30°C or hydraulic oil temperature is lower than 0°C and stay on this rpm until warm up . By this way early wearing of main components beginning engine in the first place is prevented. However if there is emergency and machine is required to be moved quickly , such function can be cancelled by pressing button on display panel.

Automatic Malfunction Indication:

When machine displays any malfunction, code representing such malfunction appears on display panel for warning purpose.

Malfunction Messages Memory:

Opera Control System has feature of keeping occurred malfunctions in the machine in its memory.

Fuel filter Congestion Warning:

Notifies water in fuel filter to operator by view.

Manuel Mode Selection:

In case of any malfunction in control system of the machine, it is possible to switch to manual mode and continue operation by means of a button located near fuse box. Hydraulic pump flow rate is fixed and also engine rpm can be set between 900 rpm and maximum rpm manually.

Component Information and Main Setting Values:

Information regarding serial numbers of the components of the machine can be loaded on the control unit and may be recalled when required. It is also possible to read the required malfunction information on the display panel through the control unit during fault searching.

Program Loading and Modification:

There are computer connection ports on control unit of the machine. By means of such ports, programs of which parameters are either the same or different can be loaded on the machine.

AUXILIARY FEATURES

Automatic Powerboost:

When more power than normal working conditions is needed, electronic control system allows working at high performance through increasing system pressure.

Automatic Powershift:

If more power is needed during digging and travel , required power is obtained by mounting engine rpm and pump flow rate above setup value

Automatic Idling:

While levers are in the middle position, in case of no movements at levers, electronic control system decreases engine rpm to 1200 rpm and then decrease to idling in order to prevent redundant fuel consumption . Automatic Idling function can be activated also at any time determined by operator. When operator touches to lever , engine rpm and pump flow rate of previously selected mode is restored . This function can be canceled by operator if he desires. By this way desired power from engine can be obtained.

Condition Information:

Many parameters such as; battery voltage , engine load, pump pressures , cooling water temperature, and hydraulic oil temperature can be monitored

Maintenance Information:

There is warning system that informs operator about periodic maintenance time automatically. Also parameters related with machine maintenance can be monitored on control panel.

Operation Hours:

Detail working hours of machine , such as working hours, travel hours, attachment hours , breaking hours, are kept on the memory.

Anti-Theft System:

Anti-theft system is set up by defining private code for each operator.

Language Selection:

Selection of multi-language on the remote control panel.



Since the very first phase of its design, the new generation GEN Series Excavators has been developed so that the user could control the machine with an extraordinary ease, in an environment of total comfort, feeling himself like in his own office.

That is why, GEN - the new generation of excavators HİDROMEK, for first time in its class, has been equipped with OPERA (HİDROMEK Operator Interface).

OPERA user interface, especially developed for the GEN series HİDROMEK excavators, which integrates all the control devices on an aesthetically designed and ergonomically located console. The system consists of a high resolution (HD) coloured TFT screen, an Electronic Control Unit and the Opera Control Unit.

With OPERA it is extraordinary easy to manage functions such as:

- Engine RPM control
- Navigate in the menus
- Choose the most appropriate working mode
- Control the lights and wipers
- Manage radio/MP3
- Start-Stop the engine to ensure maximum fuel economy.
- Control of the cameras – rear view and on the arm (optional)
- Monitoring the machine conditions, such as hydraulic pressure, engine coolant and hydraulic oil temperature, turbo boost pressure, fuel pressure, atmosphere pressure and others.
- Error Codes
- Times of work - as a time of excavating, work with attachments (breakers etc), travel, etc.
- Time to the next maintenance among others.



EXCAVATOR



Coloured TFT Display



Instrument Panel

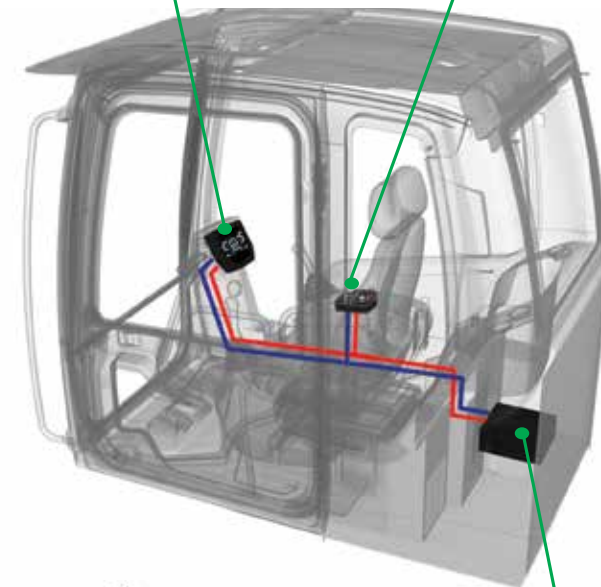

Electronic Control Unit





HYDRAULIC SYSTEM

Features:

- Easy to control
- High efficiency
- Generation of required flow rate when needed (negative control)
- Continuous control of power generation depending on increasing load
- Maximum performance under all sorts of working conditions due to functional power modes
- Priority allowance in attachment movements
- Regeneration of flow rate in main control valve

Main Hydraulic Pump

Machine performance and pump life have been maximized by using two axial pistons and variable displacement hydraulic pumps from Kawasaki, a worldwide leading hydraulic pump manufacturer. It is possible to generate the necessary flow rate when required thanks to the negative control feature. By matching the power generated from diesel engine and the power required by the hydraulic pump under increase load, engine stalls is prevented. The best matching of the engine and pump flow rate is achieved with the power mode modulation depending on working conditions. By this way;

- High efficiency
- High quality
- Long and trouble-free operating life is achieved.

Main Control Valve

The main control valve ensures sensitive and vibration free operation in each combined movement. The operator is able to focus only on his work since the priority at the arm, boom and swing movements are provided automatically by the control valve, thus maximizing efficiency. The re-regenerative system prevents cavitations during boom, arm and bucket movements and increases both the life of the hydraulic system and speed of the machine.

Holdin valves on the boom and arm are supplied as standard equipments in order to balance the interior leakage between spool and body so the potential leakage problem at the attachments is avoided. Thanks to the two-staged main relief valve, it is possible to increase the power whenever is required.

Inside the main control valve, there is straight travel valves. Due to the featured structure of the main valve block, it is possible to join the oil produced by both pumps within the valve group. There is no need for an external pipe or hose for such operation.

An additional valve section is available for breaker or other optional attachments.

Swing Hydromotor and Gearbox

An axial piston type hydromotor with high torque is used together with a heavy duty type gearbox. The hydromotor features shock absorbing valves specially designed to provide smooth and vibration free swing movement. The braking of the swing movement is provided by an oil type spring-driven park brake system.

Other features

The hydraulic accumulator which enables lowering of the attachments in case of emergency (i.e. diesel engine or main hydraulic pump failure) is located in the pilot line.

The advanced hydraulic system provides easy maintenance and thus decreases spare part costs.

Hydraulic cylinders are designed with a cushioning system to provide a vibration and shock free operation.

The entire hydraulic system is fitted with high capacity filters so ensure absolute cleanliness.

Different types of breakers may be fitted by selecting desired flow rate and pressure on the control unit.

TECHNICAL SPECIFICATIONS

EXCAVATOR

ENGINE

Emission Class	: Stage III-A (Tier 3), (UNECE R96)	: Stage III-B (Tier 4 interim)
Brand, Model	: ISUZU AI-4HK1X	: ISUZU AI-4HK1X
Type	: Water cooled diesel engine, 4 cycles, 4 cylinders, line-type, direct injection, turbocharger and intercooler	: Water cooled diesel engine, 4 cycles, 4 cylinders, line-type, direct injection, turbocharger and intercooler
Power	: 172 HP (128,4 kW) @2000 rpm / SAE J1995 (Gross) : 162 HP (120,7 kW) @2000 rpm / SAE J1349 (Net)	: 172 HP (128,4 kW) @2000 rpm / SAE J1995 (Gross) : 162 HP (120,7 kW) @2000 rpm / SAE J1349 (Net)
Maximum Torque	: 677 Nm @1500 rpm (Gross) : 656 Nm @1500 rpm (Net)	: 674 Nm @1500 rpm (Gross) : 653 Nm @1500 rpm (Net)
Displacement	: 5193 cc	: 5193 cc
Bore x Stroke	: 115 mm x 125 mm	: 115 mm x 125 mm
This new engine complies with the Emission Regulations U.S EPA Tier III and EU Stage III-A		This new engine complies with the Emission Regulations U.S EPA Tier 4 interim and EU Stage III-B

HYDRAULIC SYSTEM

Main Pump	
Type	: 2 axial piston type pumps with double variable displacement and inclined plate
Max. Flow Rate	: 2 x 233 lt/min
Pilot Pump	: Gear type, 20 L/m (10 cc/rev)
Working Pressures	
Cylinders	: 330 kgf/cm ²
Power Boost	: 350 kgf/cm ²
Travel	: 350 kgf/cm ²
Swing	: 240 kgf/cm ²
Pilot	: 40 kgf/cm ²
Cylinders	
Boom	: 2 x \varnothing 125 x \varnothing 85 x 1,325 mm
Arm	: 1 x \varnothing 140 x \varnothing 100 x 1,640 mm
Bucket	: 1 x \varnothing 125 x \varnothing 85 x 1,060 mm
Bucket (220LC LR)	: 1 x \varnothing 100 x \varnothing 70 x 910 mm

LUBRICATION

A central lubrication system is available in order to lubricate difficult-to-reach points such as boom and arm.

SUB-FRAME

Construction	: "X" type lower frame, pentagon box type side frame
Shoe	: Triple grouser
No. of Shoes	: 2 x 49 units
No. of Lower Rollers	: 2 x 9 units
No. of Upper Rollers	: 2 x 2 units
Track Tensioning	: Hydraulic type with spring cushioning

SWING SYSTEM

Motor	: Axial piston motor with integrated super shock absorbing valve, with fixed displacement and inclined plate
Reduction	: 2 stage planetary gear type
Swing Brake	: Hydraulic, disc type with warning
Swing Speed	: 10,8 rpm

CAB

- Improved operator's all round visibility
- Increased cabin internal space
- Use of six viscomount cabin mountings that dampen the vibrations
- High capacity A/C
- Cooled storage room
- Glass holder, book and object storage pockets
- Pool type floor mat
- Improved operator's comfort through versatile adjustable seat
- Ergonomically redesigned cabin through relocated switch board, and re-styled travel pedals and levers

ELECTRICAL SYSTEM

Voltage	: 24 V
Battery	: 2 x 12 V / 100 Ah
Alternator	: 24 V / 50 A
Starting Motor	: 24 V / 5,0 kw

FILLING CAPACITIES

Fuel Tank	: 354 L	Engine Oil	: 20,5 L
Hydraulic Tank	: 258 L	Swing Reducer	: 5 L
Hydraulic System	: 295 L	Travel Reducer	: 2x5,3 L
Engine Cooling Sys,	: 29,3 L		

TRAVEL AND BRAKES

Travel	: Fully hydrostatic
Travel Motor	: Axial piston motor with 2 speed stages and inclined plate
Reduction	: Planetary gear system with 2 stages
Travel Speed	
High Speed	: 5,8 km/h
Low Speed	: 3,8 km/h
Max Traction	: 18,375 kgf
Gradeability	: 35° (70%)
Parking Brake	: Hydraulic, disc type with automatic warning
Ground pressure (600mm) 220LC	: 0,50 kgf/cm ²
Ground pressure (500mm) 220NLC	: 0,59 kgf/cm ²
Ground pressure (700mm) 220LC LR	: 0,46 kgf/cm ²

OPERA CONTROL SYSTEM

- Easy-to-use control panel and menu
- Improved fuel economy and productivity
- Maximum efficiency by selection of power and work modes
- Automatic powerboost switch-on and switch-off
- Overheat prevention and protection system without interrupting the work
- Automatic electric cut-off
- Maintenance information and warning system
- Error mode registry and warning system
- HiDROMEK Smartlink (Optional)
- Anti-theft system with personal code
- Auto-Idle and automatic deceleration system
- Automatic powershift to improve performance
- Selection of multi-language on control panel
- Real time monitoring of operational parameters such as pressure, temperature, engine load
- Automatic preheater
- Possibility to register 26 different operating hours
- Rear-view, arm-view camera (Optional)

WEIGHT

Standard machine operating weight (220LC)	: 23.350 kg
Standard machine operating weight (220NLC)	: 23.100 kg
Standard machine operating weight (220LC LR)	: 25.250 kg

Operational weight, complying with the ISO 6016 standards, includes full fuel tank, hydraulic system and other liquids, 75kg operator weight and standard equipped machine weight. Optional equipments are not included.

ACCESSORIES



STANDARD BUCKET

HEAVY DUTY TYPE

	
Width	1.200 mm
Capacity	*1,00 m ³
Weight	800 kg
Number of teeth	5
ARM	*2,92 m
	2,40 m



* Standard

OPTIONAL BUCKET SELECTION DIAGRAM

											
600 mm	750 mm	900 mm	1050 mm	1200 mm	1400 mm	600 mm	750 mm	900 mm	1030 mm	1110 mm	1370 mm
0,41 m ³	0,54 m ³	0,69 m ³	0,84 m ³	1,00 m ³	1,20 m ³	0,40 m ³	0,52 m ³	0,67 m ³	0,82 m ³	0,90 m ³	1,20 m ³
510 kg	580 kg	650 kg	700 kg	780 kg	950 kg	510 kg	600 kg	670 kg	720 kg	750 kg	860 kg
3	3	4	4	5	5	3	3	4	4	4	5
A	A	A	A	A	B	A	A	A	A	A	B
A	A	A	A	B	A	A	A	A	A	A	C

Note: Single radius buckets and rock type buckets are available

BREAKOUT FORCES

			
SAE	Arm length	*2,92 m	2,40 m
	Bucket digging force (power boost)	13.700 (14.600) kgf	13.700 (14.500) kgf
	Arm breakout force (power boost)	11.200 (11.900) kgf	12.700 (13.500) kgf
ISO	Bucket digging force (power boost)	15.400 (16.400) kgf	15.400 (16.300) kgf
	Arm breakout force (power boost)	11.500 (12.200) kgf	13.100 (13.900) kgf

* Standard

STANDARD BUCKET

HEAVY DUTY TYPE

	
Width	780 mm
Capacity	0,45 m ³
Weight	460 kg
Number of teeth	3
ARM	6,1 m
	A

* Tilt angle 2 x 35°

DITCH CLEANING BUCKETS

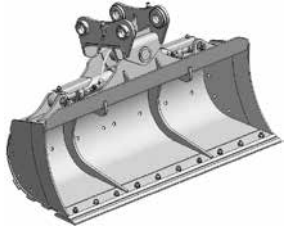
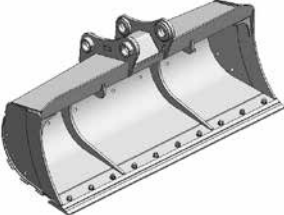
	
*Tilting Bucket	
Width	1.500 mm
Capacity	0,45 m ³
Weight	530 kg
Number of teeth	-
ARM	A
	A

BREAKOUT FORCES

		
SAE	Arm length	6,1 m
	Bucket digging force	6.500 kgf
	Arm breakout force	4.600 kgf
ISO	Bucket digging force	7.300 kgf
	Arm breakout force	4.700 kgf

- A- Material density less than 2.000 kg/m³
- B- Material density less than 1.800 kg/m³
- C- Material density less than 1.500 kg/m³
- D- Material density less than 1.200 kg/m³

WARNING

• Optional attachment and accessory standards offered with machines may differ according to countries.
• Please consult your authorized dealer to provide attachments and accessories.

LIFTING CAPACITIES

EXCAVATOR

HMK 220LC Boom: 5,8 m, Arm: 2,92 m, Bucket: 1,00 m ³ (SAE), Shoe: 600 mm											↑ :Front		↶ :Side	
A, m	Load Unit	1,5		3,0		4,5		6,0		7,5		Maximum Reach		
B, m		↑	↶	↑	↶	↑	↶	↑	↶	↑	↶	↑	↶	A, m
7,5	kg											*3400	*3400	6,75
6,0	kg									*4100	3450	*3250	*3200	7,79
4,5	kg							*4900	*4900	*4550	3350	*3300	2650	8,43
3,0	kg			*12150	*12150	*7550	*7500	*5850	4700	*5000	3200	*3450	2350	8,78
1,5	kg			*6050	*6050	*9400	6750	*6800	4350	5000	3000	*3750	2250	8,85
0 (Ground)	kg			*7300	*7300	*10550	6300	6900	4050	4800	2850	3850	2250	8,66
-1,5	kg	*6750	*6750	*10750	*10750	*10800	6100	6700	3950	4750	2800	4150	2450	8,19
-3,0	kg	*10600	*10600	*15050	12450	*10250	6150	6700	3950			4900	2900	7,38
-4,5	kg			*12400	*12400	*8700	6350	*6150	4100			*6000	4000	6,10

HMK 220LC LR Boom: 8,5 m, Arm: 6,1 m, Bucket: 0,45 m ³ , Shoe: 700 mm											↑ :Front		↶ :Side	
A, m	Load Unit	3,0		6,0		9,0		12,0		Maximum Reach				
B, m		↑	↶	↑	↶	↑	↶	↑	↶	↑	↶	R, m		
9,0	kg									*1000	*1000	*800	*800	12,18
6,0	kg									*2150	1900	*800	*800	13,52
3,0	kg					*4200	*4200	*2950	*2950	*2450	1700	*850	*850	14,11
0 (Ground)	kg	*2300	*2300	*6000	4500	*3700	2500	*2600	1500	*1050	*1050	*1050	*1050	14,04
-3,0	kg	*3350	*3350	*6800	3950	3800	2200	2450	1350	*1400	1100	1100	1100	13,29
-6,0	kg	*4950	*4950	*6600	3900	3700	2100			*2200	1400	1400	1400	11,75
-9,0	kg	*7050	*7050	*5250	4200	*3150	2300			*3150	2300	2300	2300	9,01

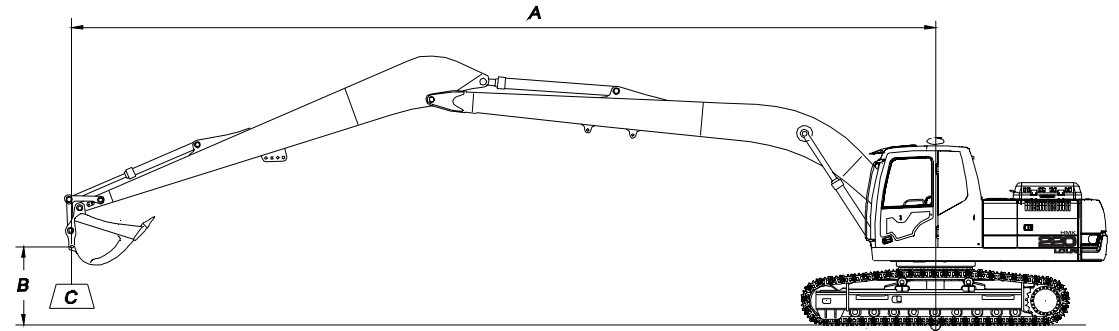
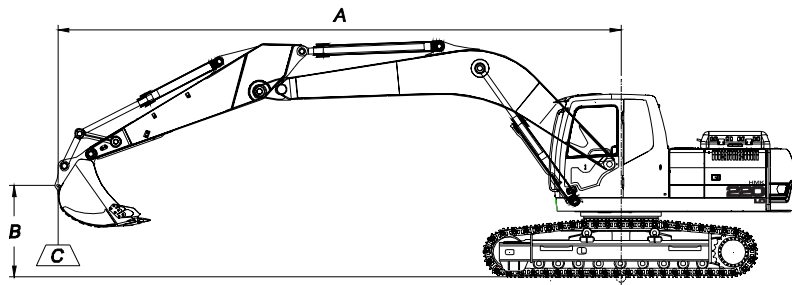

- A Load Radius
- B Load Point Height
- C Lifting Capacity

WARNING

HİDROMEK has the right to modify the specifications and design of the model indicated on this brochure without prior notice.

Notes

1. Lifting capacities are according to SAE J1097 and ISO 10567.
2. Load point is load linkage point on the bucket.
3. Lifting capacity cannot exceed 75% of over tipping capacity or 87% of full hydraulic capacity.
4. Values marked with (*) are limited by hydraulic capacity.

DIMENSIONS

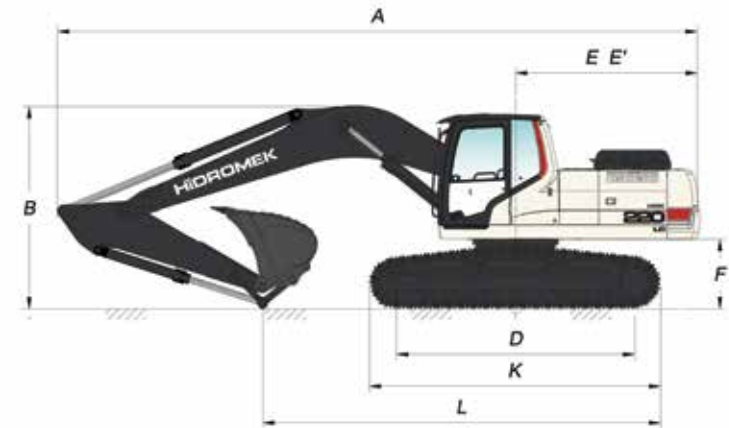
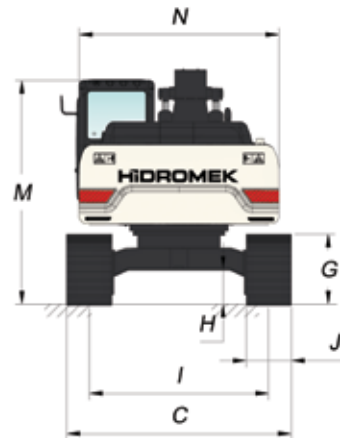
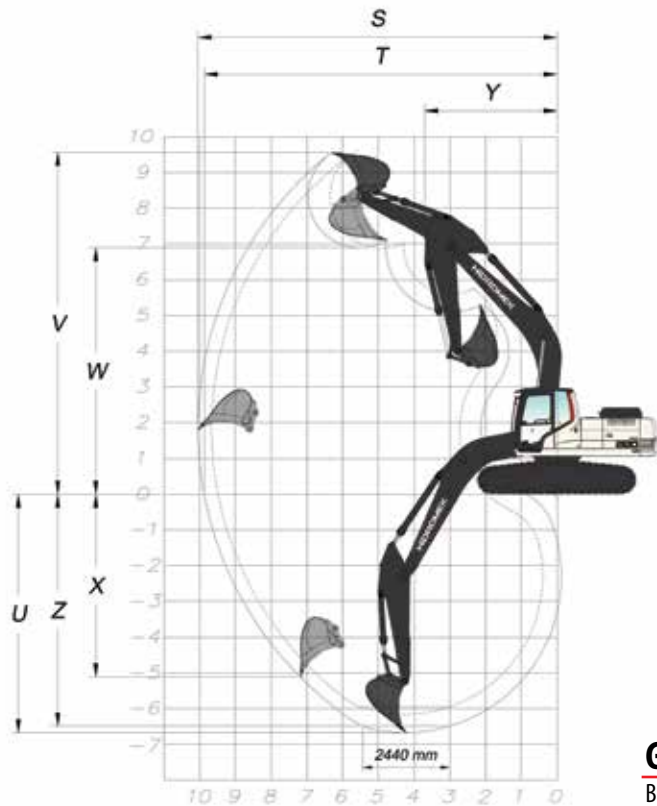

GENERAL DIMENSIONS

Boom Dimension	5.800 mm		
Arm Dimension	2.400 mm	*2.920 mm	3.500 mm
A - Overall Length	9.860 mm	9.850 mm	9.870 mm
B - Boom (Shipping) Height	3.170 mm	3.170 mm	3.380 mm
C - Lower Frame Width	2.990 mm		
D - Track Base Length	3.640 mm		
E - Counterweight Distance	2.820 mm		
E' - Counterweight Turning Radius	2.840 mm		
F - Upper Chassis to Ground Clearance	1.060 mm		
G - Crawler Height	940 mm		
H - Ground Clearance	470 mm		
I - Track Gauge	2.390 mm		
J - Shoe Width	600 mm		
K - Lower Chasis Length (from shoe)	4.460 mm		
L - Shipping Length	6.030 mm	5.430 mm	5.090 mm
M - Cab Height	3.010 mm		
N - Upper Frame Width	2.660 mm		

* Standard

WORKING DIMENSIONS

Boom Dimension	5.800 mm		
Arm Dimension	2.400 mm	*2.920 mm	3.500 mm
S - Maximum Reach Distance	9.660 mm	10.070 mm	10.620 mm
T - Maximum Reach at Ground Level	9.490 mm	9.900 mm	10.460 mm
U - Maximum Digging Depth	6.170 mm	6.690 mm	7.270 mm
V - Maximum Digging Height	9.550 mm	9.580 mm	9.910 mm
W - Maximum Unloading Height	6.790 mm	6.870 mm	7.170 mm
W' - Minimum Unloading Height	3.050 mm	2.530 mm	1.950 mm
X - Maximum Vertical Wall Digging Depth	5.130 mm	5.310 mm	6.020 mm
Y - Minimum Swing Radius	3.790 mm	3.750 mm	3.670 mm
Z - Maximum Digging Depth (2440 mm level)	5.980 mm	6.510 mm	7.120 mm

* Standard

220LC LR DIMENSIONS

EXCAVATOR

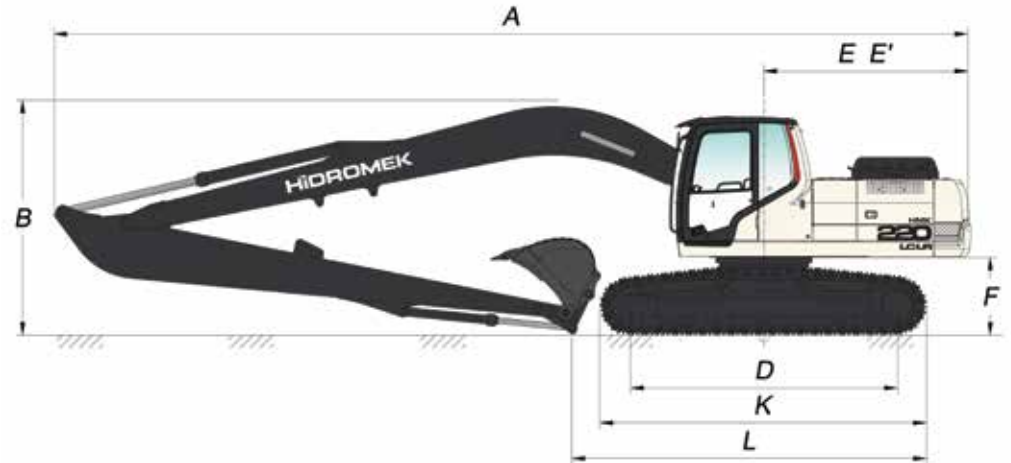
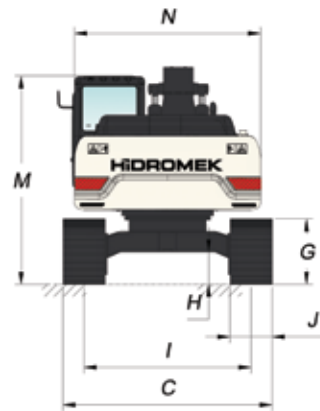
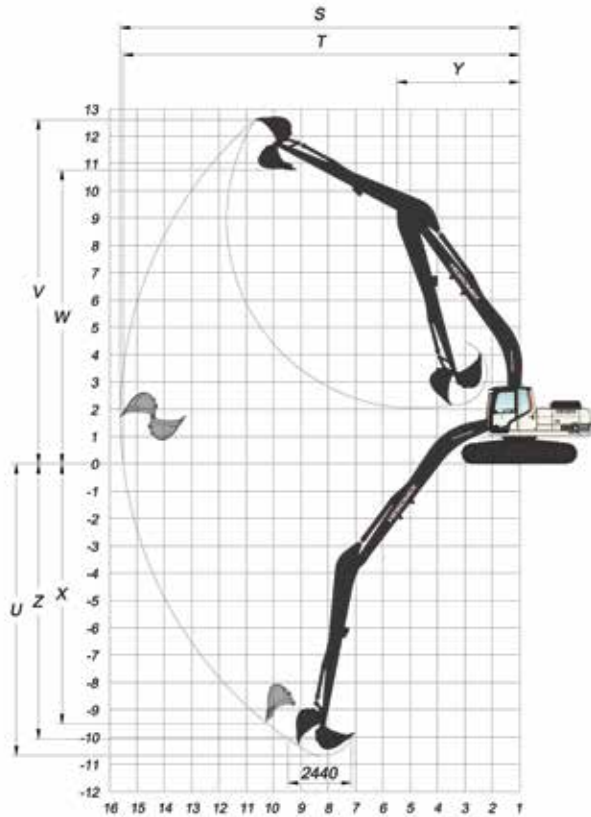

GENERAL DIMENSIONS

Boom Dimension	8.500 mm
Arm Dimension	6.100 mm
A - Overall Length	12.470 mm
B - Boom (Shipping) Height	3.200 mm
C - Lower Frame Width (Track Width)	2.990 / 3.090 / *3.190 mm
D - Track Base Length	3.640 mm
E - Counterweight Distance	2.890 mm
E' - Counterweight Turning Radius	2.920 mm
F - Upper Chassis to Ground Clearance	1.065 mm
G - Crawler Height	935 mm
H - Ground Clearance	465 mm
I - Track Gauge	2.390 mm
J - Shoe Width	600 / 700 / *800 mm
K - Lower Chassis Length (from shoe)	4.460 mm
L - Shipping Length	5.420 mm
M - Cab Height	2.985 mm
N - Upper Frame Width	2.660 mm

* Standard

WORKING DIMENSIONS

Boom Dimension	8.500 mm
Arm Dimension	6.100 mm
S - Maximum Reach Distance	15.170 mm
T - Maximum Reach at Ground Level	15.060 mm
U - Maximum Digging Depth	11.240 mm
V - Maximum Digging Height	13.170 mm
W - Maximum Unloading Height	10.850 mm
X - Maximum Vertical Wall Digging Depth	9.270 mm
Y - Minimum Swing Radius	3.520 mm
Z - Maximum Digging Depth (2440 mm level)	11.130 mm

* Standard

DETAILS

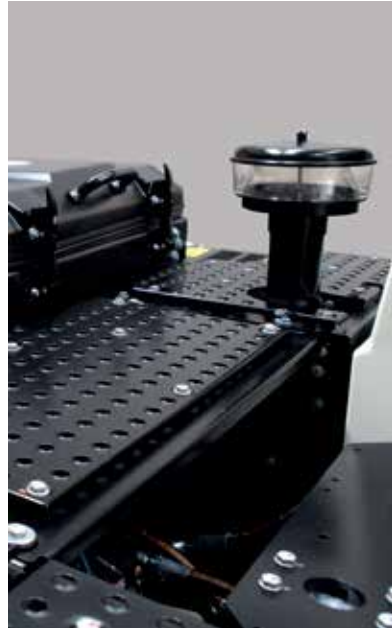



Special Equipment List

- 2,4 m arm
- Various size buckets
- Automatic lubrication system
- Rotator line
- Boom safety valve
- Arm safety valve
- Overload warning system
- Beacon lamp
- 700, 800 mm track
- Hydraulic breaker
- Hydraulic Quick Coupler
- Ripper
- Windscreen protective netting
- Headlights
- HIDROMEK Smart Link
- Rotational moving hydraulic shear installation
- Air suspension seat with heated

Standard Equipment List

- Radio/MP3
- Air conditioner
- Cab heating system
- Cab conforming to FOPS tests
- Computer connection port
- Oil and dust seal ring in chain pins
- Long life lubricating in rollers and direction wheel
- Fuel transfer pump
- Front air filter
- Double air filter
- Automatic idling
- Engine pre-heating facility
- Overheating, low engine pressure, air filter clogging indicators
- Battery charge warning system
- Hydraulic breaker line
- Camera
- Tool box
- Working lighth on counterweighth
- Additional working lamp at the front
- Additional working lamp at the rear
- Air suspension seat

HIDROMEK®

HIDROMEK HEAD OFFICE

Address : Ahi Evran OSB Mahallesi Osmanlı Caddesi No:1
06935, Sincan - Ankara / TURKEY
Phone : +90 312 267 12 60 • **Fax:** +90 312 267 12 39
E-mail : ihracat@hidromek.com.tr

HIDROMEK RUS

Address : 72, Zhivopisnaya str., Building A, village
Oktyabrskiy, Krasnodar, 350032, RUSSIA
Phone : +7 861 290 3007
E-mail : info@hidromek.ru

HIDROMEK THAILAND

Hidromek Construction Equipment Ltd.
Address : No: 700/669 Moo 1, T. Phanthong
A. Phanthong, Chonburi 20160, THAILAND
Phone : +66 38 447 349 • **Fax:** +66 38 447 355

HIDROMEK WEST

Address : C/De La Maquina 14, Poligono Industrial El Regás,
08850 - Gavá BARCELONA/ SPAIN
Phone : +34 93 638 84 65 • **Fax :** +34 93 638 07 14
E-mail : info@hidromek.es

HIDROMEK JAPAN

Address : 5-10, Hashimoto 6-chome, Midori-Ku,
Sagamihara, Kanagawa, 252-0143 JAPAN
Phone : +81 42 703 0261 • **Fax:** +81 42 703 0262

www.hidromek.com

Your Local Distributor:

WARNING
HIDROMEK has the right to modify the specifications and design of the model indicated on this brochure without prior notice.