



**NEW!**

### ENGINE

Make	: Mercedes-Benz MTU6R1000
Type	: High power and torque output, water cooled, turbocharged diesel engine.
Number of Cylinders	: 6 in line
Bore & Stroke	: 110 x 135 mm
Displacement	: 7.700 cc
Maximum Power	: 282 HP (210 kW) @2000 rpm
Maximum Torque	: 1200 Nm @ (1200 - 1600 rpm)
Conforms to European Stage V exhaust gas emission regulations	

### TRANSMISSION

- Autoshift transmission for heavy duty service
- 5 forward, 3 reverse gears
- Torque converter with 2.194:1 stall ratio
- 4 Wheel Drive
- Transmission oil cooler
- Engine start only at the gear lever on neutral position for safety.
- Electronic parking brake

### HYDRAULIC SYSTEM

Closed center type hydraulic system with LS type variable displacement piston type pumps.

Pump Flow	: 270 L/min @1900 rpm
Pressure	: 270 bar

### DRIVING SPEED

@1900 rpm engine speed

1 <sup>st</sup> gear next	: 6,12 km/h
2 <sup>nd</sup> gear next	: 11,41 km/h
3 <sup>rd</sup> gear next	: 17,50 km/h
4 <sup>th</sup> gear next	: 27,09 km/h
5 <sup>th</sup> gear next	: 41,30 km/h
1 <sup>st</sup> gear back	: 6,47 km/h
2 <sup>nd</sup> gear back	: 12,03 km/h
3 <sup>rd</sup> gear back	: 28,53 km/h

### AXLES

- Heavy duty type ZF axles
- Planetary type reduction gears
- Total 26 degrees oscillation on the rear axle
- Equipped with differential lock on the front axle

### CAB & HOOD

- Widened visual angle
- Ergonomic & Aesthetic Interior Design
- 8" LCD coloured touchpad display
- Improved Opera Control System
- Externally servicable Air Conditioner system
- Cool-box
- Electro hydraulic control levers
- ROPS and FOPS certificated cab
- 35° tilting cab for maintenance
- Air suspension seat with heating
- TIPSHIFT control on operator console
- Pool type floor mats
- Tablet PC and phone holder
- SmartLink (Optional)
- Storage boxes for operator
- Sun-wisors
- LED headlamps
- LED working lighths
- Electrically controlled side mirrors with heating
- Rear view camera
- One-piece opening hood, electrically controlled.
- Independently adjustable joystick console and armed

### TIRES

Front / Rear : 23,5 - R25

### OPERATING WEIGHT

Standard machine operating weight : 20.450 kg

Operational weight, complying with the ISO 6016 standards, includes full fuel tank, hydraulic system and other liquids, 75 kg operator weight and standard equipped machine weight. Optional equipments are not included.

# HMK 635 WL

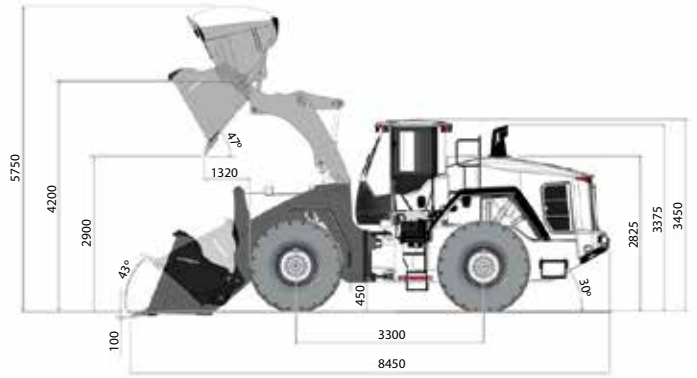
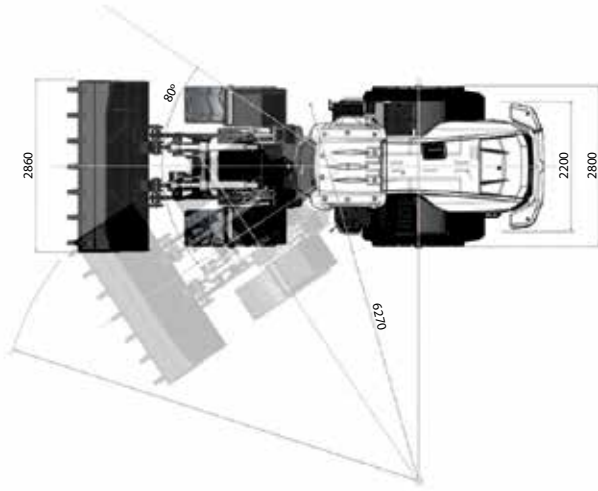

## PERFORMANCE

Bucket capacity	3,5 m <sup>3</sup>
Max. breakout force	17650 kgf
Static tipping load (no tire deflection)	15500 kgf
Static tipping load- articulated (no tire deflection)	13600 kgf

## FILLING CAPACITIES

Fuel tank	: 275 L
Hydraulic Tank	: 115 L
Hydraulic System	: 200 L
Engine Cooling System	: 40 L
Engine oil	: 28,5 L
Front Axle	: 41,5 L
Rear Axle	: 40 L
Transmission	: 43 L
Diesel Engine Fluid (Adblue®)	: 40 L

## LINKAGE

- Z-bar
- Auto-lift
- Return to Dig (RTD)
- Auto bucket Kick-out

## HYDRAULICS

- Load sensing steering and hydraulics
- Ride Control System (MSS)
- Proportional and bi-directional hydrostatic fan
- Emergency steering system
- Easy acces to pressure measure mant points

## ELECTRICAL AND LIGHTING

- 24 V
- Batteries 2 x 12 V, 1200 CCA
- Alternator, 100 A
- LED headlamps
- LED working lamps (4 front, 4 rear, 2 hood)
- LED stoplights
- Ignition key, start stop switch
- 12 V outlet
- Reverse Alarm
- Main disconnect switch

**HIDROMEK**

### FACTORY - HEAD OFFICE

Ahi Evran OSB Mahallesi Osmanlı Caddesi No:1 06935 Sincan / ANKARA / TURKEY  
Tel: (+90) 312 267 12 60 Fax: (+90) 312 267 12 39  
www.hidromek.com

Notice:  
Hidromek has the right to modify the specifications and design of the model indicated on this brochure without prior notice.